

**STANLEY**  
Engineered Fastening

Avdel UK Limited  
Stanley House, Works Road  
Letchworth Garden City, Hertfordshire SG6 1JY  
Tel. +44 1582 900-000 · Fax -001  
enquiries2@sbdinc.com

**STANLEY**  
Engineered Fastening



Find your closest STANLEY Engineered Fastening location on  
[www.stanleyengineeredfastening.com/contact](http://www.stanleyengineeredfastening.com/contact)  
For an authorized distributor nearby please check  
[www.stanleyengineeredfastening.com/econtact/distributors](http://www.stanleyengineeredfastening.com/econtact/distributors)

Manual Number	Issue	C/N
07900-09303	E	17/010



## Instruction Manual

- EN Hydro-Pneumatic Blind Rivet Nut Tool
- AR أداة تثبيت صواميل البرشام العمياء المانبة الهوائية
- BG Хидропневматичен инструмент за слепи нит-гайки
- CZ Hydro-pneumatické nýtovací nářadí na slepé nýtovací matice
- EL Υδροπνευματικό εργαλείο τοποθέτησης τυφλών πριτσινιών με σπειρώμα
- ET Hüdorpneumaatiline tõmbemutri tangid
- HR Hidro-pneumatski alat za slijepe zakovice
- HU Hidropneumatikus szegecsanya behúzó szerszámgép
- LT Hidropneumatinis kniedytuvas
- LV Hidropneimatiskais vītņu kniedētājs
- RO Dispozitiv hidro-pneumatic pentru piulițe nituibile oarbe
- RU Пневмо-гидравлический инструмент для заклёпочных гаек
- SK Hydro-pneumatické nářadie na umiestňovanie slepých nitových matic
- SL Hidro-pnevmatiko orodje za slepe kovice
- TR Hidro-Pnömatik Somun PerçinAleti

© 2018 Stanley Black & Decker, Inc.

Holding your world together®, Avdel®, Eurosert®, Nutsert®, Hexsert® and Squaresert® are registered trade marks of Avdel UK Limited. ProSert® is a trade mark of Avdel UK Limited. POP Nut® is a registered trade mark of Newfrey LLC.

The names and logos of other companies mentioned herein may be trademarks of their respective owners. Data shown is subject to change without prior notice as a result of continuous product development and improvement policy. Your local STANLEY Engineered Fastening representative is at your disposal should you need to confirm latest information.

ProSert® XTN20 Blind Rivet Nut Tool – 74202

# Hydro-Pneumatic Power Tool

**POP** X Avdel

Fig. 1

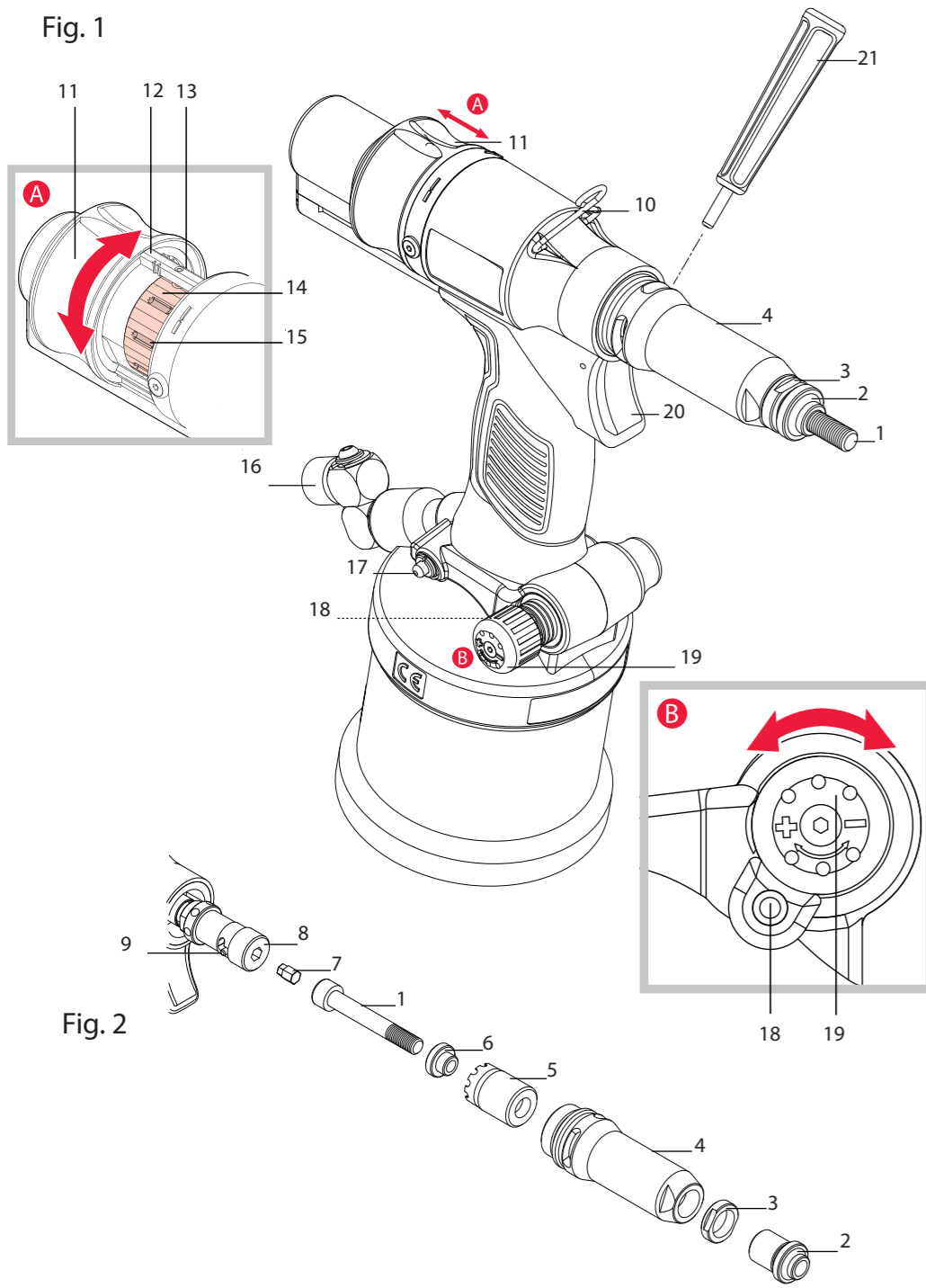

Fig. 3

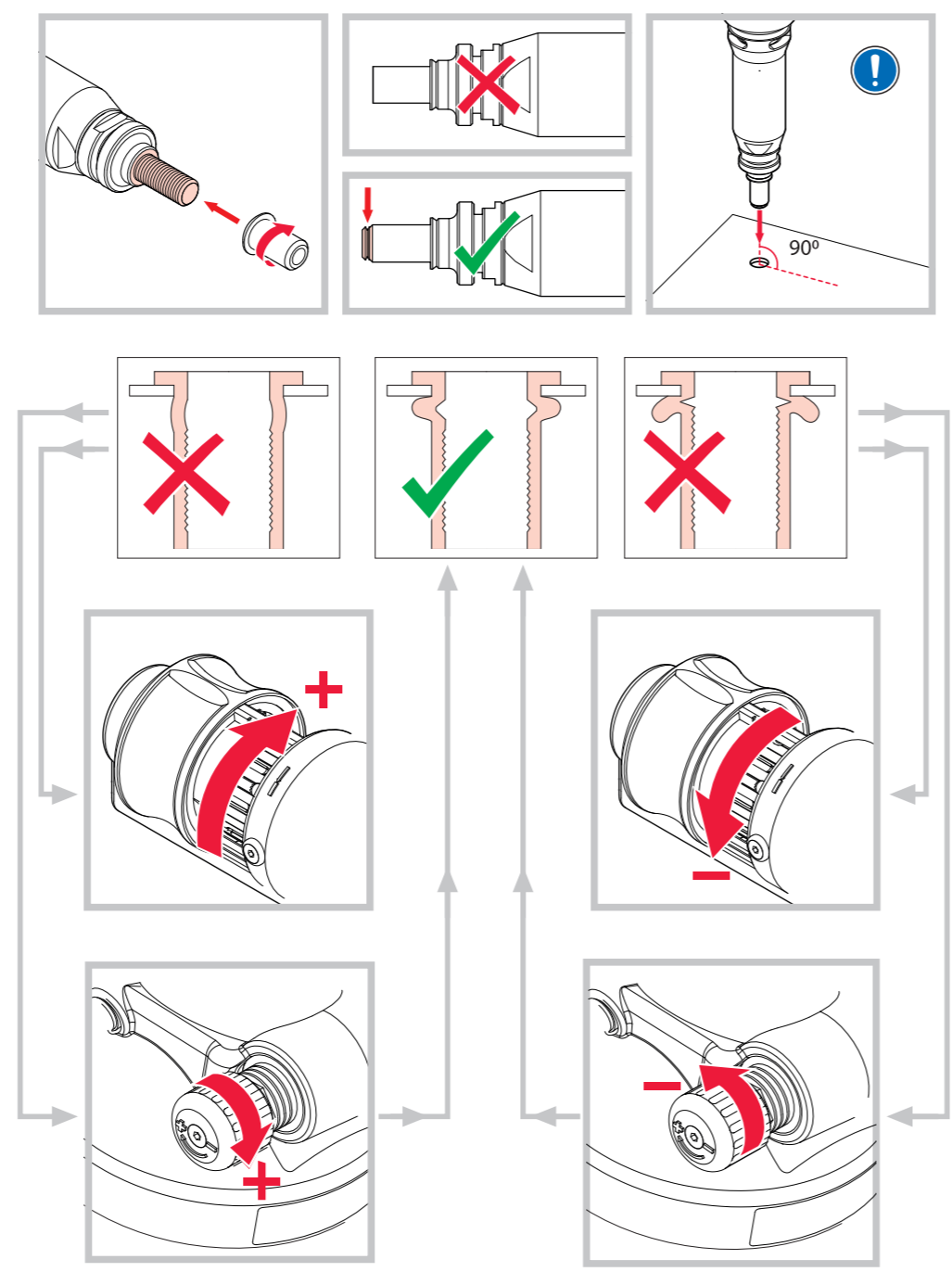

Fig. 2

